

BALCO INC

410 E 37th St N, Suite A • Wichita, Kansas 67219
Phone: (316) 945-9328 • Fax: (316) 945-0789

***INSTALLATION INSTRUCTIONS
FOR BALCO, INC. TRENCH AND ACCESS COVER
TST/ACT-X-500 W/LINER
FOR CAST-IN-PLACE INSTALLATION***

INSTALLATION INSTRUCTIONS FOR BALCO, INC. TST-X-500 & ACT-X-500 W/LINER TRENCH COVER & ACCESS COVER SYSTEMS

The following installation instructions are very important. Read them carefully, and be sure you understand them completely before you begin any work.

STORAGE & HANDLING

The trench cover system may require some assembly. Store this product in the horizontal position in a clean, dry location. This is a finished product. Store this product in a protected area. Do not stack anything on these stored Trench and/or Access Covers.

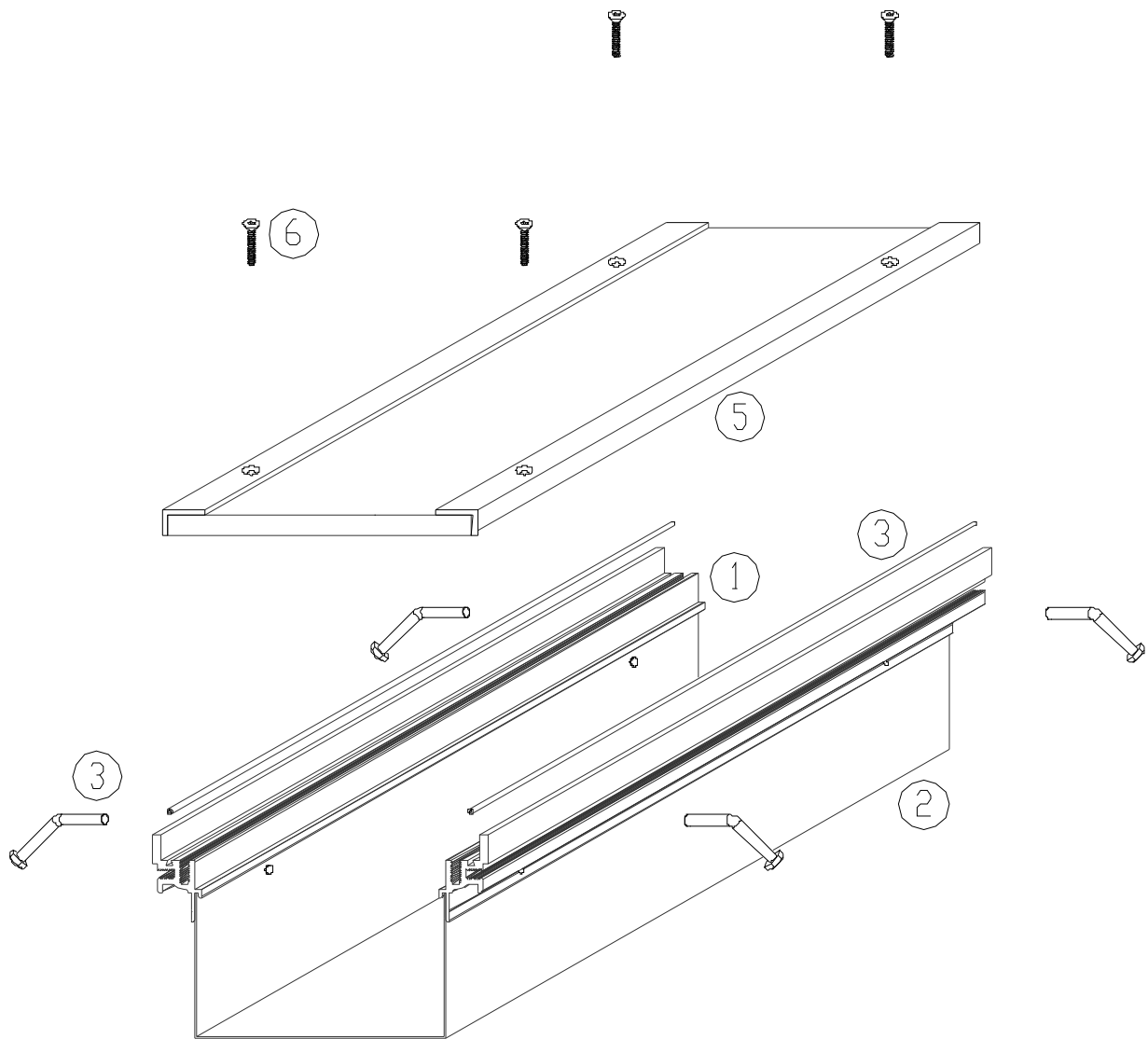

Figure 1

TST-X-500 & ACT-X-500 PARTS LIST¹

1. Frame
2. Liner²
3. Cast-In Frame Anchors
4. Cushions
5. Cover Plate
6. Cover Plate Bolts

¹ This system number is representative. The system number indicates cover plate surface finish, thickness, and width.

² The Liner is typically steel, but aluminum and stainless steel are also available.

TOOLS REQUIRED

This is a list of tools and materials recommended for use in the installation of these joint cover systems. These tools and materials are not provided by Balco, Inc.

- A. Wooden Bracing
- B. Plywood for temporary replacement of cover
- C. Electric Drill
- D. Drill Bits for metal (aluminum and steel)
- E. Drill Bits for drilling wood.
- F. Drill Bits for drilling concrete.
- G. Sockets for hex head screws
- H. Phillip's Head Drill Bit
- I. Air Gun for clearing debris and dust from installation area
- J. Rivet Gun
- K. Silicone Sealant
- L. Hammer
- M. Nails or wood screws for assembling bracing

INSTALLATION

These installation instructions are for use in the installation of Balco, Inc. TST/ACT-X-500 W/Liner Series Trench and Access Cover Systems. These instructions are for cast-in-place systems. The system is illustrated in Figure 1. These systems shall be installed as follows:

STEP 1. Review Balco, Inc. approved shop drawings for types and locations.

STEP 2. Pour the concrete support pad, if required. Ensure that the support pad is the proper width, thickness, elevation, configuration, and length. Ensure that the top surface of the pad is level.

NOTE: BALCO, INC. RECOMMENDS THAT A CONCRETE SUPPORT PAD BE USED FOR INSTALLATION OF CAST-IN-PLACE TRENCH & ACCESS COVERS. HOWEVER OTHER METHODS FOR INSTALLING CAST-IN-PLACE TRENCH & ACCESS COVERS MAY BE USED AND ARE ACCEPTABLE, PROVIDED THE SELECTED METHOD IS GOOD, STANDARD INDUSTRY PRACTICE AND PROVIDED THE SELECTED METHOD CONFORMS TO ALL APPLICABLE STANDARDS AND REQUIREMENTS.



Figure 2

STEP 3. Attach the anchors (part no. HB14212) to the trench cover or access cover frame, spacing the anchors at 20" o.c. (see Figure 2).

STEP 4. Assemble the trench cover on the support pad, splicing the liner and frame sections of the assembly in accordance with the procedures provided in the appropriate sections of these installation instructions (see Figure 3). Refer to the section of these instructions entitled "SPLICING TRENCH AND ACCESS COVER FRAMES" and the section of these instructions entitled "SPLICING TRENCH LINERS" for procedures for assembling the frames and liners. Place the trench cover into the assembled frame. Ensure that the cover is properly aligned in the frame.

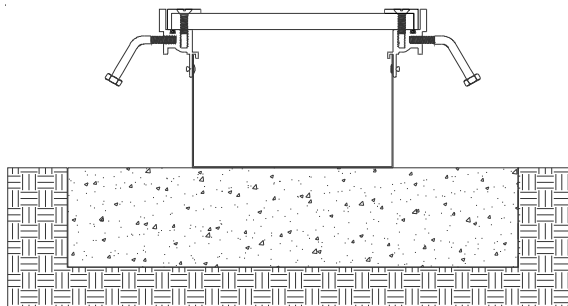

Figure 3

NOTE: TRENCH COVER SYSTEMS MUST BE INSTALLED FULLY ASSEMBLED TO ENSURE THE PROPER ALIGNMENT OF ALL THE SYSTEM COMPONENTS.

STEP 5. Remove the cover plate from the frame (see Figure 4).

STEP 6. Provide continuous wooden bracing inside the trench liner (see Figure 5). This will help ensure that the assembly maintains its shape during the pouring, finishing and curing of the concrete.

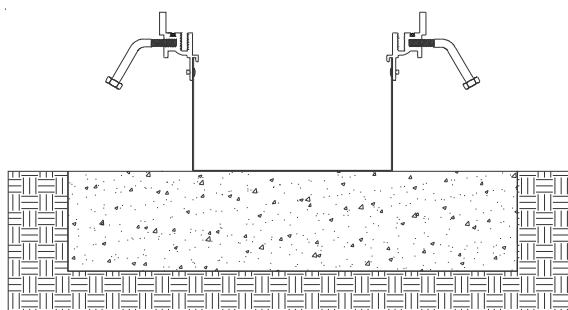

Figure 4

NOTE: IT WILL BE NECESSARY TO DRILL ANCHOR HOLES INTO THE TEMPORARY WOODEN COVER SO THAT IT MAY BE ATTACHED TO THE TRENCH COVER FRAME.

STEP 7. Caulk all splices, etc. with silicone caulk to provide additional moisture protection.

STEP 8. Place a temporary wooden cover (plywood is recommended) into the frame, attaching it to the frame as shown in Figure 5. This procedure is recommended to protect the cover plate from concrete splatter during the pouring and finishing of the concrete.

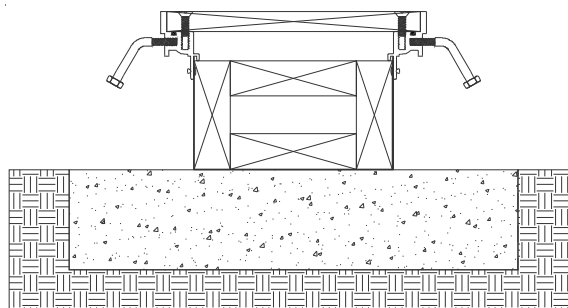

Figure 5

STEP 9. Ensuring that the trench cover or access cover assembly is in the proper position, that it is level, and that it will not shift during the pouring or finishing of the concrete, affix the assembly to the support pad. The assembly may be wired into place or otherwise affixed in place.

STEP 10. Pour the concrete in accordance with standard industry practice and all applicable requirements. Clean away any excess concrete from the exposed surfaces of the frame before the concrete is allowed to cure.

STEP 11. After the concrete has cured, remove the temporary wooden cover from the frame and remove the wooden bracing from the liner (see Figure 6).

STEP 12. Place the trench cover plate back into position in the frame. Ensure that each section of the cover plate is properly aligned and in the proper position.

STEP 13. Using the fasteners (part no F1434S) provided by the factory, attach the cover plate to the frame (see Figure 7).

STEP 14. Install the tile into the cover plate recess at the time of installation of the finished floor (see Figure 8). Install the tile in accordance with the tile and adhesive manufacturers' instructions.

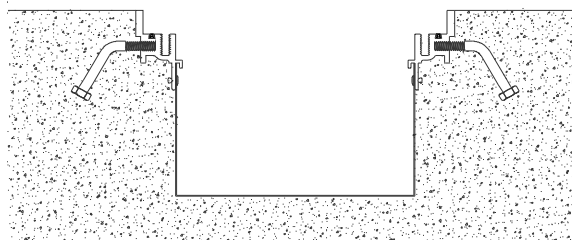

Figure 6

SPLICING TRENCH & ACCESS COVER FRAMES

Splice bars used to splice trench & access cover frames are fabricated by the factory. Splice bars are provided with factory drilled anchor holes.

STEP 1. Select a section of the trench cover frame and place it into its installed position. Ensure that the frame is level, the proper width, flush with the finished floor, and properly aligned.

STEP 2. Place a mating section of the frame into its assembled position relative to the frame section already put into place.

STEP 3. Abut the mating sections of the frame together as tightly as possible (see Figure 9). Ensure that the system is level, even, the proper width, flush with the finished floor, and properly aligned.

STEP 4. Select a splice bar and place it into position on the frame so that the splice bar traverses the splice and so that the splice is centered behind the splice bar (see Figure 10).

STEP 5. Attach the splice bar to the to the frame sections using the fasteners (part no. H1412S) provided by the factory (see Figure 11).

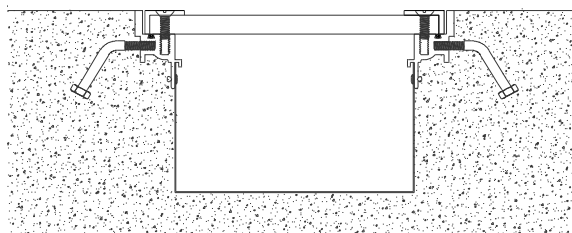

Figure 7

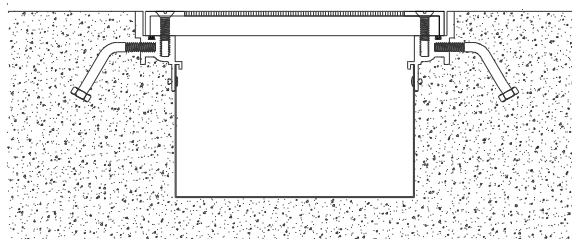

Figure 8

STEP 6. Complete each splice in the frame using the procedures given in this section of these installation instructions.

STEP 7. Splice the trench liner in accordance with the procedures provided in this section of these installation instructions.

STEP 8. Complete the trench or access cover system installation in accordance with the procedures provided in these installation instructions.

SPLICING TRENCH LINERS

Splice plates for the trench liners are fabricated by the factory and are attached to the inside of one of the mating sections of the trench liner at the factory. The splice plates may be spot welded to the liner or they may be riveted to the liner. The splice plates extend beyond the section of the trench liner to which they are attached so that they can be inserted into the mating section of the trench liner. Trench liners are typically attached to the trench cover frames at the factory. Refer to the section of these instructions entitled "Splicing Trench & Access Cover Frames" for the procedures necessary to splice the trench cover or access cover frames.

STEP 1. Remove the sections of the trench cover plate from their corresponding sections of the trench cover frame and liner.

STEP 2. Select a section of the trench liner and place it into its installed position. Ensure that the liner is level, even, and properly aligned.

STEP 3. Place a mating section of the liner into its assembled position relative to the liner section already put into place (see Figure 12).

STEP 4. Place a continuous bead of silicone caulk (by others) on the exposed outside surface of the splice plate at a nominal 1" from the plate's end.

STEP 5. Slide the free end of the attached splice plate into the receiving end in the mating section of the trench liner (see Figure 13). Ensure that the mating sections of the trench liner are level, the proper width, and properly aligned. Ensure that the mating sections of the liner abut as closely as possible with one another.

STEP 6. Press the splice plate and the mating section of the liner together to spread the caulk and to form a better seal.

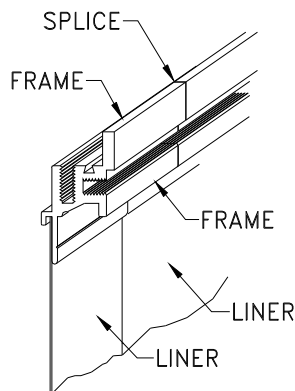

Figure 9

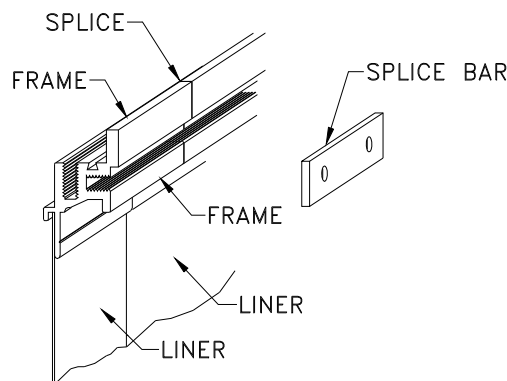

Figure 10

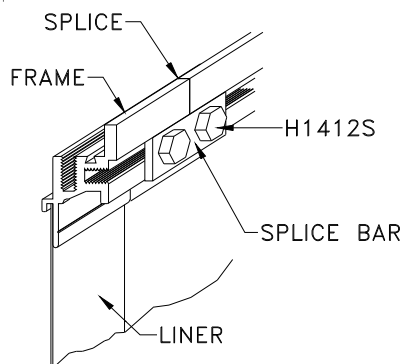

Figure 11

STEP 7. Caulk the splice with silicone caulk (by others) to provide additional moisture protection.

STEP 8. Spot weld or rivet the free end of the splice plate to the mating section of the trench liner, ensuring that the mating sections of the trench liner remain as tightly abutted together as possible (see Figure 14).

STEP 9. Repeat Step 3 through Step 8 of this section of these installation instructions for each subsequent section of the trench liner until the liner is completely assembled.

STEP 10. Splice the trench cover frames, as needed, in accordance with the appropriate procedures given in these installation instructions.

STEP 11. Complete the installation of the trench cover or access cover system in accordance with the procedures given above in these installation instructions.

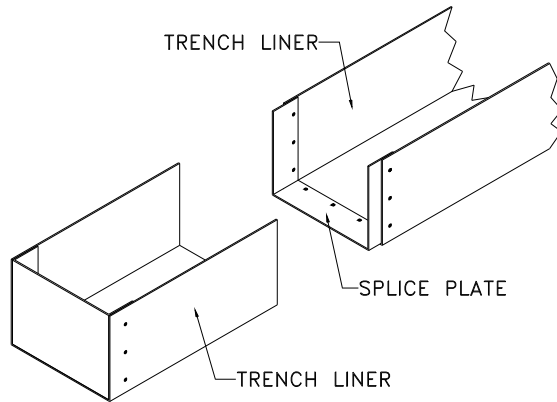

Figure 12

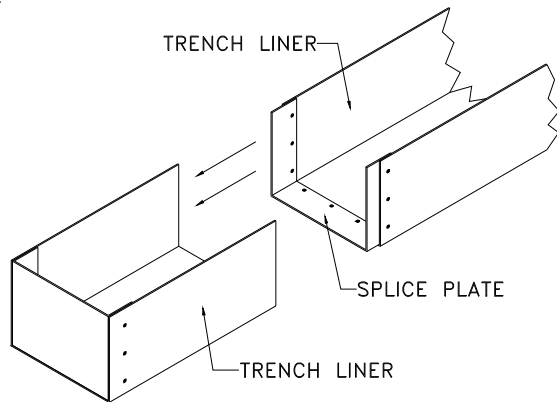

Figure 13

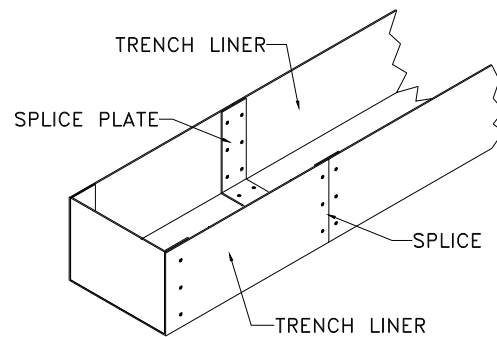

Figure 14